

# E-Z-GO

## D1161 - PDS Sepex Motor/Controller Options

### Terrain Color Codes



Speed sensor plug on motor does NOT match E-Z-GO OEM PDS motor



Use sensor cable with D1161 & E-Z-GO OEM PDS & GE controllers only, Not needed with Alltrax controllers

**3228** Sensor Cable

**D1161**  
PDS Motor, 4.45 HP



### Application: Non-Lifted Cars

**489** - **300 amp** Alltrax  
replaces 73326-G05 & others



Replacement for stock controller

**490** - **400 amp** Alltrax  
up to 24 mph, Added Torque



Added torque & speed

**592** - **500 amp** Alltrax  
up to 24 mph, Extra Torque



Extra torque & speed

**561** - **600 amp** Alltrax  
Up to 24 mph, Maximum Torque



Maximum torque & speed

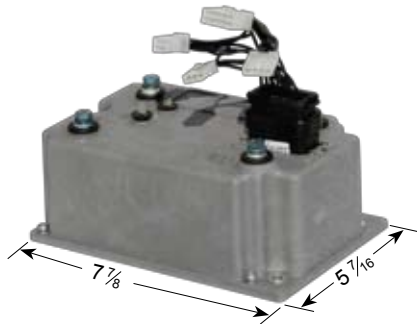

**604** - **300 amp** GE for PDS  
*Up to 23 mph, Standard Torque*  
use with PDS Stock Motor & D1161



Replacement for stock controller,  
Increased speed

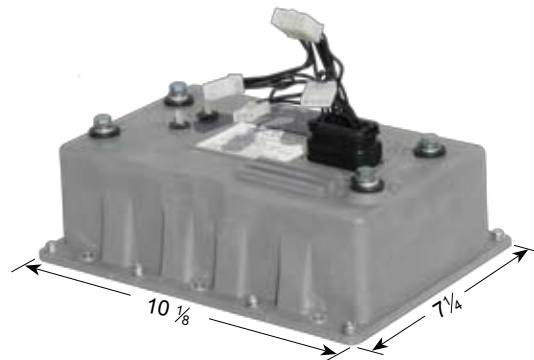

**633** - **500 amp** GE for PDS  
*Up to 23 mph, Extra Torque*  
use with PDS Stock Motor & D1161



Maximum torque, increased speed  
Use if car has 4-Passenger Kit or  
Utility Box

\* For maximum performance, safety, and durability, 4 gauge cables throughout the car & H.D. solenoid are required  
△ Use on car with four passenger kit or utility box